



**"Packaging Automation Systems"**  
Boston • Amsterdam • London • Chicago • San Jose • Singapore



innovate.

solve.



imagine.



lead.



**"A global company to believe in."**

# Durataper 32FC Mini™



## *automatic case sealers*

The new Durataper 32 FC Mini™ automatically folds the top flaps and seals them with tape. The mini is designed for applications with minimal floor space and is priced extremely competitive. Features include the automatic flap closing, compact welded frame with adjustable legs, O/K taping heads with fixed tape feed path and safety guarding. Options are 3" tape heads and casters.

The OKI Group is a leading global supplier of integrated "end of the line" packaging automation systems. Our technology, process optimization and services help our customers achieve their productivity and business goals.



**O/K Durable Packaging Inc.**  
5117 Dansher Road  
Countryside, IL 60525 USA  
tel: 708.387.2253  
fax: 708.387.2211  
[sales@okdurable.com](mailto:sales@okdurable.com)

## Technical Specifications for DURATAPER 32FC MINI:™

|                     |  |
|---------------------|--|
| Case range:         | 8.00" x 6.00" x 5.00" (L x W x H) min.<br>16.00 x 16.00 x 16.00" (L x W x H) max.  |
| Case weight:        | Up to 50 lbs.  |
| Belt speed:         | 60ft./min.   |
| Throughput:         | Up to 30 cases/min. Case sealers require spacing of 18.00" or more between cases. If this spacing cannot be maintained a separating system will be required. |
| Finish:             | Steel-it painted.  |
| Taping heads:       | O/K Blue Max 2" tape head.   |
| Air requirement:    | 45 PSI, 2 CFM with a 1/4" supply.  |
| Power requirements: | 110 VAC, 1 Ph, 60Hz, 5.6 Amp.  |
| Side belts:         | 2.50" wide, self-centering side belts.   |
| Motors:             | Two 1/6 HP motors.   |
| Table height:       | 26.00" - 32.00".   |
| Machine dimension:  | 57.75" x 43.86" x 57-1/8" to 67-1/8".  |
| Pneumatic:          | 45 PSI, 2 CFM  |

## FEATURES

## BENEFITS

|                               |  |
|-------------------------------|--|
| Centralized case adjustments. | Fast and easy size change improves efficiency.   |
| Heavy-duty welded frames.     | Durable construction for demanding applications. |
| Steel-it painted finish.      | Resist weather, staining and chemicals.          |
| Short, compact time.          | Applications with minimal floor space.           |

The DURATAPER 32FC Mini is usually combined with a Duraformer case erector:



OKCORP.COM

### DURATAPER 32FC MINI LAYOUT

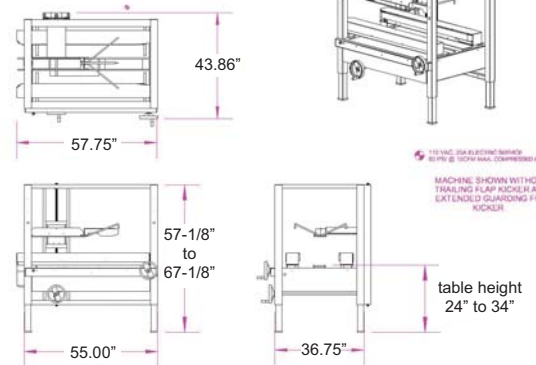

### DURATAPER 32-FC™ Mini OPTIONS:

- Reverse directions.
- Interlock guarding.
- Optional O/K Blue Max 3" tape head.
- Compression wheels.
- Entrance tables/conveyors.
- Exit conveyors.
- Low tape alarm.
- Customer specified finish.
- Casters.
- Full steel roller bed.