

CHICAGO TAPERS™



CHICAGO TAPERS™

CHICAGOTAPERS.COM

CHICAGOTAPERS.COM

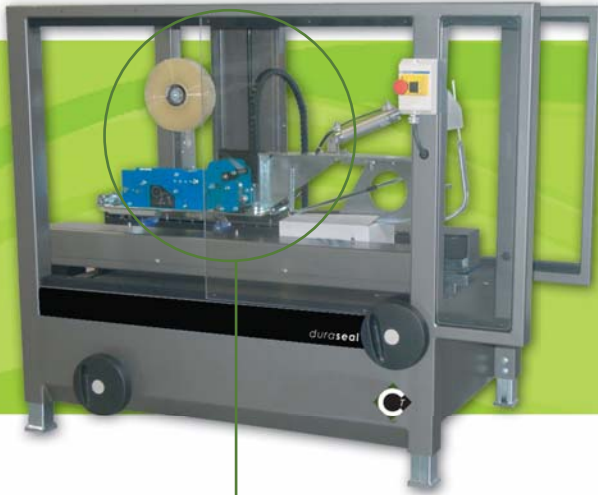
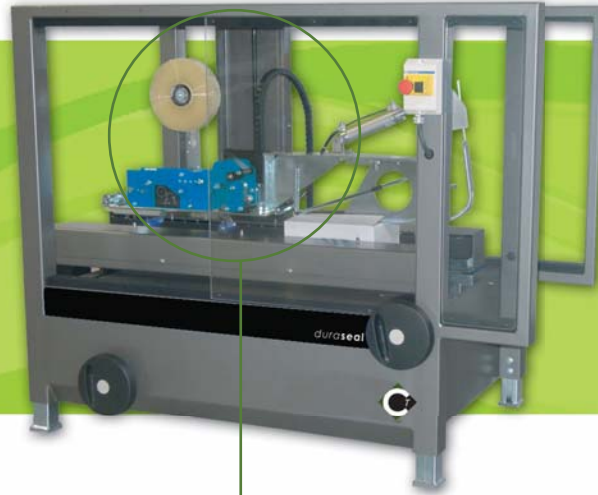

JOIN THE INNOVATION

JOIN THE INNOVATION

**CT 32-FC MINI  
AUTOMATIC CASE SEALER**

**CT 32-FC MINI  
AUTOMATIC CASE SEALER**



**CONTACT US**

-  708 - 588 - 1374
-  708 - 588 - 1625
-  [sales@chicagotapers.com](mailto:sales@chicagotapers.com)



## CT-32 FC MINI™ AUTOMATIC CASE SEALER

The CT-32 FC Mini™ Compact Automatic Case Sealer folds the top case flaps and seals them with tape. The "Mini" is designed for applications with minimal floor space and is priced extremely competitive. Features include the automatic flap closing, compact welded frame with adjustable legs, Chicago Taper taping heads with open tape feed path and safety guarding. Options are 3" tape heads and casters.

### TECHNICAL SPECIFICATIONS FOR THE CT-32 FC MINI:

Case range:	min. 8" x 6" x 5" max. 16" x 16" x 16" (L x W x H)
Belt speed:	60ft./min.
Case weight:	Up to 50 lbs.
Throughput:	Up to 15 cases/min. Case sealers require spacing of 18" or more between cases. If this spacing cannot be maintained a separating system will be required.
Finish:	Steel-it painted.
Taping heads:	Blue Max taping heads for 2".
Power requirements:	110 VAC, 1 Ph, 60 Hz, 5.6 Amp. or to requirement.
Side belts:	2.50" wide, self-centering side belts.
Table height:	26" - 32".
Machine dimension:	57.75" x 43.86" x 57 - 1/8" to 67 - 1/8" (L x W x H)
Pneumatic:	45 PSI, 2 CFM
Motors:	Two 1/6 HP motors.
Air requirement:	45 PSI, 2 CFM with a 1/4" supply.

### CT-32 FC MINI OPTIONS:

- Reverse direction.
- Interlock guarding.
- Blue Max 3" tape head
- Compression wheels.
- Entrance tables/conveyors.
- Exit conveyors.
- Low tape alarm.
- Customer specified finish.
- Casters
- Full steel roller bed.

### FEATURES

Centralized case adjustments.	Fast & easy size change improves efficiency.
Heavy - duty welded frames.	Durable construction for demanding applications.
Steel - it painted finish.	Resist weather, staining and chemicals.
Short, compact time.	Applications with minimal floor space.

### BENEFITS

### THE CT-32FC MINI IS USUALLY COMBINED WITH A DURAFORMER CASE ERECTOR:

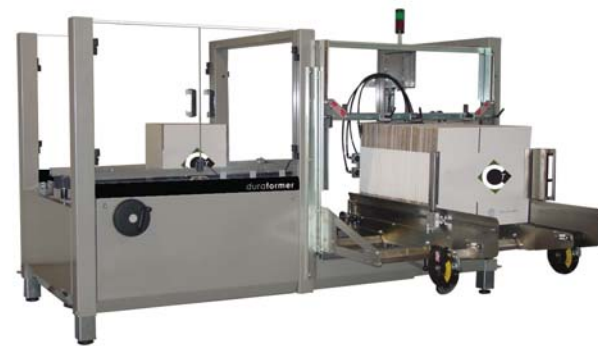

### CT-32FC MINI LAYOUT

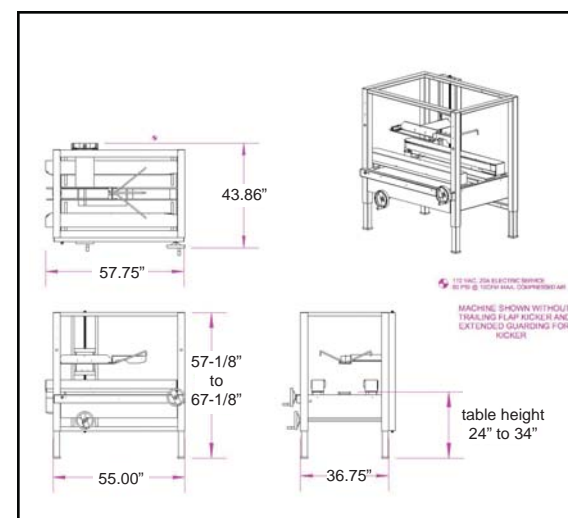

### SERVING MANY DIFFERENT INDUSTRIES:

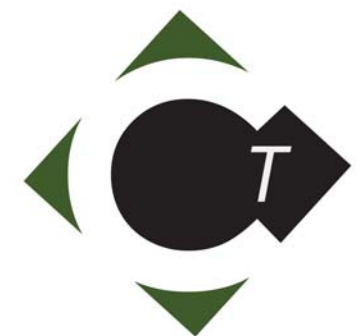

**CHICAGO TAPERS™**

Chicago Tapers  
5117 Dansher Road  
Countryside, IL 60525 USA  
tel: 708.588.1374  
fax: 708.588.1625  
sales@chicagotapers.com