

CHICAGO TAPERS™



CHICAGO TAPERS™

CHICAGOTAPERS.COM

CHICAGOTAPERS.COM



JOIN THE INNOVATION

JOIN THE INNOVATION

ACF-25
AUTOMATIC CASE FORMER

ACF-25
AUTOMATIC CASE FORMER

CONTACT US

708 - 588 - 1374
708 - 588 - 1625
sales@chicagotapers.com



ACF-25

AUTOMATIC CASE FORMER



The ACF-25 Automatic Case Former is a high performance case erector that has the ability to erect and seal cases with tape at speeds up to 30 cases per minute. The design of the ACF-25 Case Former focuses on innovation and ease-of use, providing customers with up-time reliability.

TECHNICAL SPECIFICATIONS FOR THE ACF-25:

Case range:	min. 7" x 6" x 4" max. 20" x 16" x 16" (L x W x H)
Speed:	Up to 30 cases/min.
Case Magazine:	Horizontal, belt indexing magazine.
Tape applicator:	2" wide tapehead.
Electric:	480 V, 3 phase, 60 HZ.
Pneumatic:	80 - 100 PSI @ 10 CFM.
Alarm signals:	Low tape, low case, an case monitoring sensors with 2 - color beacon.
Operator interface:	Allen - Bradley Panelview Display.
Controls:	Allen - Bradley.
Motors:	SEW .50 H.P.
Cylinders:	ISO standard cylinders.
Finish:	Painted exterior finish.
Construction:	Welded frame with 4" x 4" tubing and removable panels.
Table height:	22" - 36"
Full Safety Guarding.	

ACF-25 OPTIONS:

- Right or left hand case loading.
- Exit conveyors.
- 3" tape head.
- Customer specified finish.
- 60" or 90" belt indexing magazine.

FEATURES

High speed case erector.	Increase in production.
Automatic operation.	No operators required.
Easy load powered case magazine.	Ergonomic and efficient.
Deluxe control package.	
Heavy duty welded frames.	Machine longevity.

BENEFITS

ACF-25 LEFT HAND LAYOUT

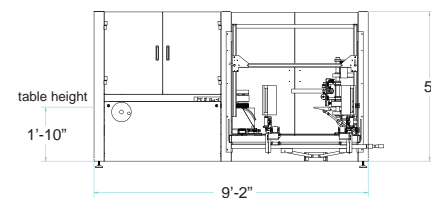
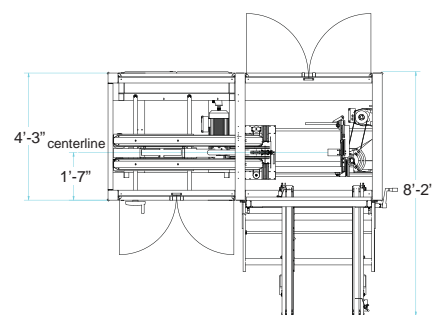

(With printing upright.)

RIGHT HAND CASE ORIENTATION



(With printing upright.)

LEFT HAND CASE ORIENTATION



SERVING MANY DIFFERENT INDUSTRIES:



CHICAGO TAPERS™

Chicago Taper
5117 Dansher Road
Countryside, IL 60525 US
tel: 708.588.137
fax: 708.588.162
sales@chicagotapers.com