

CHICAGO TAPERS™



CHICAGO TAPERS™

CHICAGOTAPERS.COM

CHICAGOTAPERS.COM



JOIN THE INNOVATION

JOIN THE INNOVATION

ACF-15
AUTOMATIC CASE FORMER

ACF-15
AUTOMATIC CASE FORMER

CONTACT US

📞 708 - 588 - 1374
📞 708 - 588 - 1625
✉️ sales@chicagotapers.com



ACF-15

AUTOMATIC CASE FORMER



The ACF-15 Automatic Case Former is a high performance case erector that has the ability to erect and seal cases with tape at speeds up to 15 cases per minute. The design of the ACF-15 Case Former focuses on innovation and ease-of use, providing customers with up-time reliability.

TECHNICAL SPECIFICATIONS FOR THE ACF-15:

Case range:	min. 8" x 6" x 5" max. 24" x 15" x 15" (L x W x H)
Speed:	Up to 15 cases/min.
Case Magazine:	Horizontal, belt indexing magazine.
Tape applicator:	High quality 2" wide tapehead.
Electric:	110 V, 1 phase, 60 HZ.
Pneumatic:	80 - 100 PSI @ 10 CFM.
Operator interface:	Selector switch with push button emergency stop.
Controls:	Allen - Bradley.
Motors:	120 RPM
Cylinders:	Numatic.
Finish:	Powder coated exterior finish.
Construction:	Welded frame with 4" x 4" tubing and removable panels.
Table height:	22" - 36"

ACF-15 OPTIONS:

- Right or left hand case loading.
- Exit conveyors.
- 3" tape head.
- Customer specified finish.
- Low tape alarm.
- Low case alarm.
- Case detection sensor
- 60"-90" belt indexing magazine.

FEATURES

Automatic operation.	No operators required.
Easy load powered case magazine.	Ergonomic and efficient.
Allen - Bradley Components.	Latest technology.
Heavy duty welded frames.	Machine longevity.

BENEFITS

SERVING MANY DIFFERENT INDUSTRIES:



ACF-15 LEFT HAND LAYOUT

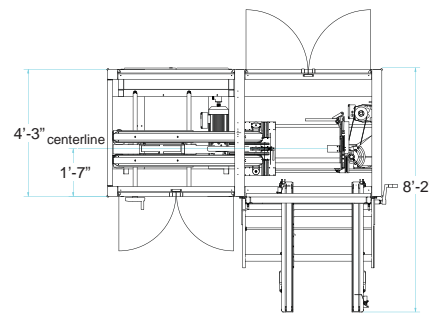

(With printing upright.)

RIGHT HAND CASE ORIENTATION



(With printing upright.)

LEFT HAND CASE ORIENTATION

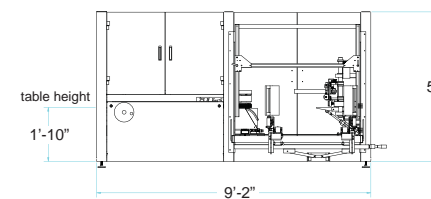
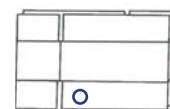

CHICAGO TAPERS™

Chicago Taper
5117 Dansher Road
Countryside, IL 60525 US
tel: 708.588.137
fax: 708.588.162
sales@chicagotapers.com