

CHICAGO TAPERS™

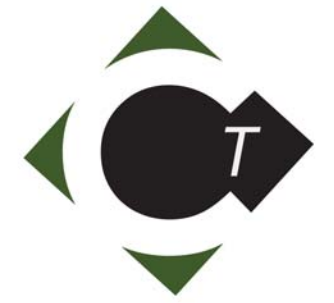

CHICAGO TAPERS™

CHICAGOTAPERS.COM

CHICAGOTAPERS.COM



JOIN THE INNOVATION

JOIN THE INNOVATION

**ACF-10**  
AUTOMATIC CASE FORMER

**ACF-10**  
AUTOMATIC CASE FORMER



**CONTACT US**

708 - 588 - 1374  
708 - 588 - 1625  
sales@chicagotapers.com



# ACF-10

## AUTOMATIC CASE FORMER

The ACF-10 Automatic Case Former erects RSC cases, bottom seals & delivers them to your conveyor at speeds up to 10 cases per minute. Exclusive features of the machine are Allen-Bradley PLC, compact welded frame, walk-in magazine, jam sensor and open face 2" tape head.

### TECHNICAL SPECIFICATIONS FOR THE ACF-10:

Case range:	min. 8" x 6" x 5" max. 20" x 16" x 16" (L x W x H)
Case types:	RSC, HSC.
Finish:	Painted exterior finish.
Taping heads:	2" wide tape head.
Table height:	22" - 32".
Speed:	Up to 10 CPM.
Power requirements:	115 VAC, 1 Ph, 60 Hz, 5.4 Amp.
Pneumatic:	80 PSI @ 8 CFM with 1/4" supply.
Controls:	Allen - Bradley.
Motors:	85 RPM.
Discharge control photo eye:	Standard.
Case monitoring sensor:	Standard.
Low cases, no cases signals:	Optional.
Low tape, no tape signals:	Optional.
Stack light:	Optional.
Inner locked guarding:	Optional.
Weight:	1600 lbs.

### FEATURES

Walk in magazine.	Ergonomic and efficient.
Quick and easy size change.	Increased production efficiency and flexibility.
Heavy-duty welded compact frames.	Durable construction for demanding applications.
Heavy-duty, easy thread, tape head.	Long lasting and efficient.
Allen-Bradley PLC.	Latest technology.

### BENEFITS

### SERVING MANY DIFFERENT INDUSTRIES:

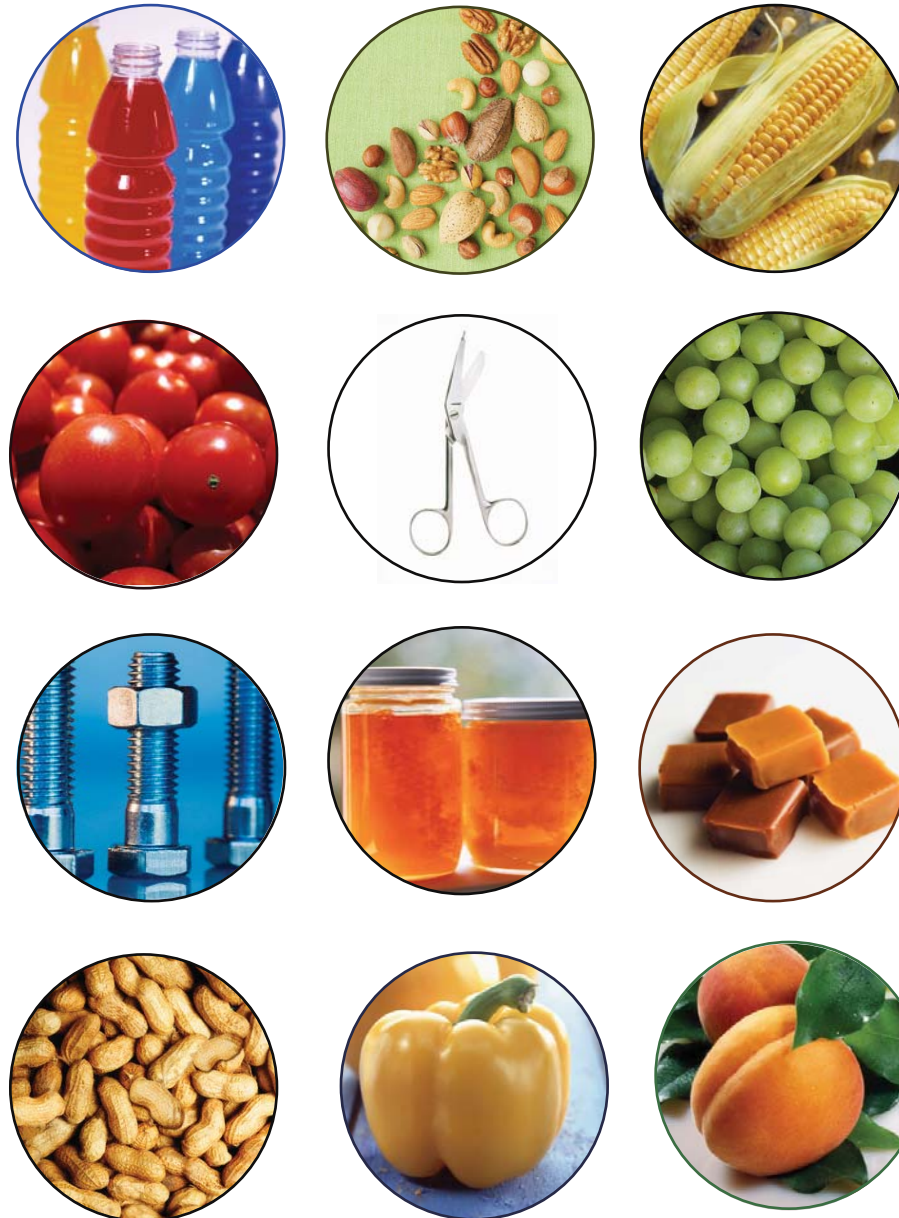

### ACF-10 OPTIONS:

- Right or left hand case loading.
- Exit conveyors.
- Nema 4 wiring.
- 3" tapehead.
- Customer specified finish.

ACF-25  
left hand layout

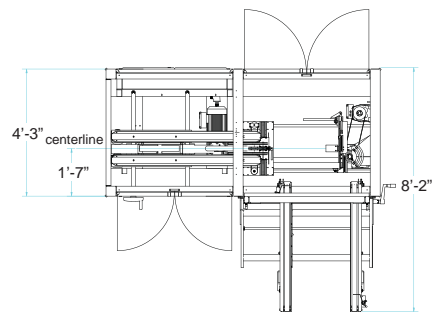

(With printing upright.)  
RIGHT HAND CASE ORIENTATION



(With printing upright.)  
LEFT HAND CASE ORIENTATION

